

STUDY OF ALTERNATE ENGINE PROPULSION SYSTEMS TO REDUCE CO₂ EMISSIONS FROM COASTAL SHIPS

Srinivas Vissamsetty and Ramesh S Updhyayula, Indian Maritime University, Visakhapatnam

SUMMARY

This paper looks into the various engine propulsion systems like conventional reciprocating engines with HFO/LNG dual fuels, direct/electric propulsion with emphasis on reducing CO₂ emissions from coastal ships. LNG is quickly emerging as a strong alternative to HFO because 20-30% reduction of CO₂ can be achieved using this fuel. This paper also looks into the necessity for considering LNG for coastal shipping. A technical analysis is carried out for the additional expenditure incurred in way of the additional/alternate equipment and the benefits due to complying with IMO's Tier II and III requirements (no need to install any other emission cleaning equipment → expenditure saved), reduced carbon foot print, reduced maintenance costs, increase in the thermal efficiency of the engine, etc. Carbon dioxide emissions from all alternatives are also presented.

NOMENCLATURE

HFO	Heavy Fuel Oil	
LNG	Liquefied Natural Gas	
CO ₂	Carbon Di Oxide	
NO _x	Nitrogen Oxides	
SO _x	Sulphur Oxides	
IMO Organisation	International Maritime	Organisation

such as gas, and developing methods to clean exhaust gases to meet tighter regulations.

Emissions from the exhaust like Nitrogen monoxide (NO) and nitrogen dioxide (NO₂) is causing acid rain leading to over-fertilization of lakes as well as smog formation. Combustion temperatures in engines have a significant influence on NO_x emissions.

Sulphur dioxide (SO₂) and sulphur trioxide (SO₃) collectively called sulphur oxides (SO_x) are contributing to acid rain with detrimental effects on vegetation, human health and buildings. SO_x emissions are proportional to the sulphur content of the fuel and its consumption.

1. INTRODUCTION

Most modern ships utilise a reciprocating diesel engine as their prime mover, due to their operating simplicity, robustness and fuel economy compared to most other prime mover mechanisms. The rotating crankshaft can be directly coupled to the propeller with slow speed engines, via a reduction gearbox for medium and high speed engines, or via an alternator and electric motor in diesel-electric vessels. From an environmental point of view, however, these engines are not the friendliest.

Global warming and the mechanism known as the Greenhouse Effect are debated in the media almost every day. The causes and effects of this phenomenon are affected to people in many ways. The marine industry is aware of public sensitivity towards green issues and is facing environmental regulations that directly influence its business. There has been much research towards developing low-emission diesel engines, using alternative fuels

Carbon dioxide (CO₂) is the principle greenhouse gas contributing to global warming of the atmosphere. It is widely believed that a 2°C increase in temperature above 1990 levels will place many unique and threatened systems, including many biodiversity hotspots, at significant risk leading to increased risk of species extinction and climate havoc. The CO₂ concentration must not exceed 450 ppm to keep the global warming within 2°C above 1990 level by 2100.

As per the International Energy Agency statistics released in 2009, India stands behind China, US and Russian Federation as the 4th largest CO₂ emitter in the world with 1427.6 million tonnes as compared to world's 28348. The emissions from Transportation sector stands at 17% of which the share of Sea Transportation amounts to around 7%.

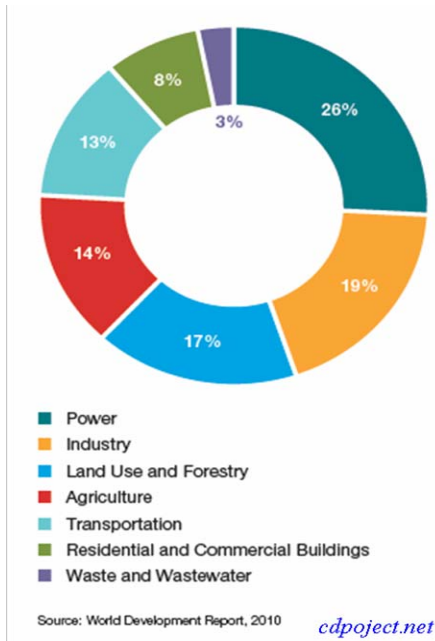

Figure-1

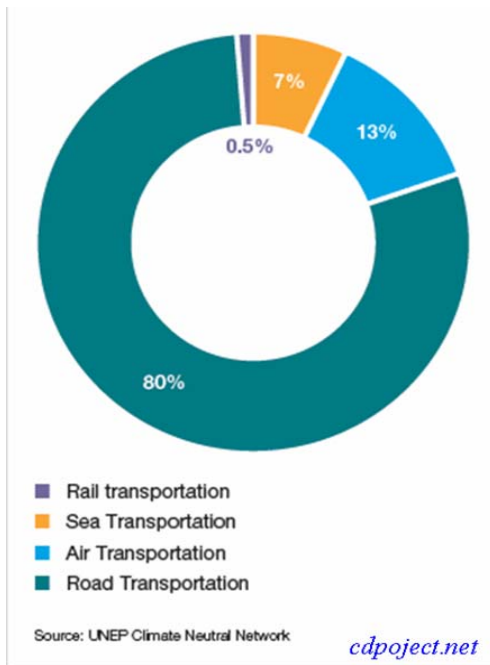

Figure-2

Shipping is responsible for a very substantial part of total global emissions of CO₂, yet at present there are no targets for limiting or

reducing these emissions. According to a 2009 United Nations' International Maritime Organisation expert group report, international shipping was in 2007 responsible for 870 million tonnes of CO₂, around 2.7% of total global CO₂ emissions. Emissions from shipping have been growing rapidly in recent years and in the absence of regulation are predicted to rise to 1,475 million tonnes (or 6% of the total) by 2020. Greenhouse gases from shipping were not included in the 1997 Kyoto Protocol targets, but developed countries (those listed in Annex I of the Protocol) are obliged to pursue reductions by working through the International Maritime Organisation (IMO). IMO is now working on design and operational standards for developing a market-based measure.

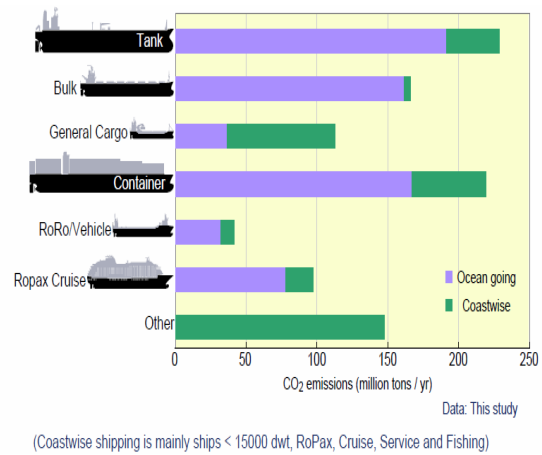

Figure-3

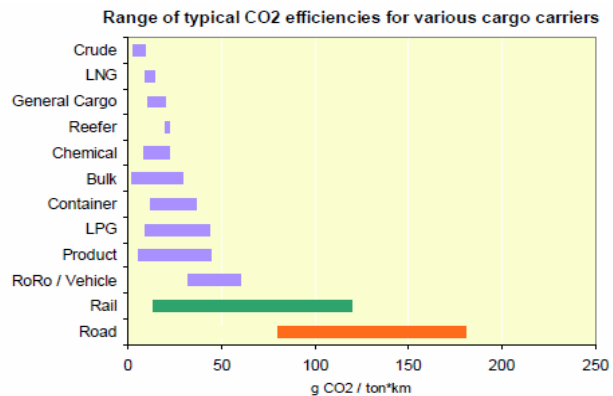

Figure-4

2. IMO RECOMMENDATIONS

The United Nations approved new rules that mandate energy efficiency and carbon emissions improvements for the shipping industry. Roughly

50,000 ships carry 90 percent of the world's trade cargo every year and these ships tend to run on heavily polluting oil known as Bunker Fuel. The United Nations International Maritime Organization (IMO) has decided to regulate both seafaring cargo and transport vessels to meet new energy efficiency and carbon emission guidelines. Unlike attempts by the U.N. to regulate carbon emissions in other sectors, this new set of rules will be applied equally to all U.N. countries regardless of whether they are industrialized or developing.

According to the IMO, shipping was responsible for 2.7 percent of global carbon emissions in 2007, but that could double or even triple by mid-century if no action is taken now. The IMO's Environmental Protection Committee concluded at a weeklong meeting that all ships built in the future must reduce pollution from today's averages. The levels of emissions reduction will be based on an efficiency index for ships of varying sizes and types.

The mandates state that shipbuilders may decide exactly how to meet the new standards. "As long as the required energy-efficiency level is attained, ship designers and builders would be free to use the most cost-efficient solutions for the ship to comply with the regulations."

The new rules mandate that ships contracted in the first five years after 2015 must improve fuel efficiency by 10%. The standards are to be tightened every subsequent five year. By 2030, a 30% reduction rate would be set for most types of ships, based on the average of those built between 1999 and 2009.

The amendments to MARPOL Annex VI Regulations for the prevention of air pollution from ships, add a new chapter 4 to Annex VI on Regulations on energy efficiency for ships to make mandatory the Energy Efficiency Design Index (EEDI), for new ships, and the Ship Energy Efficiency Management Plan (SEEMP) for all ships.

2.1 EEDI (Energy Efficiency Design Index)

Shipping is permanently engaged in efforts to optimize fuel consumption. And, while ships are universally recognized as the most fuel-efficient mode of bulk transportation, the Second IMO GHG Study, in 2009, identified a significant potential for further improvements in energy efficiency, mainly through the use of already existing technologies such as more efficient engines and propulsion systems, improved hull designs and larger ships; or, in other words, through technical and design based

measures that can achieve noteworthy reductions in fuel consumption and resulting CO₂ emissions on a capacity basis (tonne-mile). The study also concluded that additional reductions could be obtained through operational measures such as lower speed, voyage optimization, etc.

The EEDI addresses the former type of measure by requiring a minimum energy efficiency level for new ships; by stimulating continued technical development of all the components influencing the fuel efficiency of a ship; and by separating the technical and design-based measures from the operational and commercial ones. The EEDI formula – as presently drafted – is not supposed to be applicable to all ships. Indeed, it is explicitly recognized that it is not suitable for all ship types (particularly those not designed to transport cargo) or for all types of propulsion systems (e.g., ships with diesel-electric, turbine or hybrid propulsion systems will need additional correction factors).

Indeed, the first iteration of the EEDI has been purposefully developed for the largest and most energy-intensive segments of the world merchant fleet, thus embracing 72 per cent of emissions from new ships and covering the following ship types: oil and gas tankers, bulk carriers, general cargo ships, refrigerated cargo carriers and container ships.

$$EEDI = \frac{CO_2 \text{ emission}}{\text{transport work}}$$

The CO₂ emission represents total CO₂ emission from combustion of fuel, including propulsion and auxiliary engines and boilers, taking into account the carbon content of the fuels in question. If energy-efficient mechanical or electrical technologies are incorporated on board a ship, their effects are deducted from the total CO₂ emission. The energy saved by the use of wind or solar energy is also deducted from the total CO₂ emissions, based on actual efficiency of the systems.

The transport work is calculated by multiplying the ship's capacity (dwt), as designed, with the ship's design speed measured at the maximum design load condition and at 75 per cent of the rated installed shaft power.

The EEDI, in establishing a minimum energy efficiency requirement for new ships depending on ship type and size, provides a robust mechanism that may be used to increase the energy efficiency of ships, stepwise, to keep pace with technical

developments for many decades to come. It is a non-prescriptive mechanism that leaves the choice of which technologies to use in a ship design to the stakeholders, as long as the required energy-efficiency level is attained, enabling the most cost-efficient solutions to be used.

10. $f_{\text{eff}(i)}$ is the availability factor of each innovative energy efficiency technology. $f_{\text{eff}(i)}$ for waste energy recovery system should be one (1.0)

11. f_i is the capacity factor for any technical/regulatory limitation on capacity, and can be assumed one (1.0) if no necessity of the factor is granted

$$\frac{\left(\prod_{j=1}^M f_j \right) \left(\sum_{i=1}^{nME} C_{FMEi} SFC_{MEi} P_{MEi} \right) + P_{AE} C_{FAE} SFC_{AE} + \left(\sum_{i=1}^{nPTI} P_{PTIi} - \sum_{i=1}^{nWHR} P_{WHRi} \right) C_{FAE} SFC_{AE} - \left(\sum_{i=1}^{neff} f_{\text{eff}} P_{\text{eff}} C_{FMEi} SFC_{MEi} \right)}{f_i \text{ Capacity } V_{\text{ref}} f_w}$$

1. C_F – is a non-dimensional conversion factor between fuel consumption measured in g and CO₂ emission also measured in g based on carbon content

Type of Fuel	Carbon content	C_F (t-CO ₂ /t-Fuel)
Diesel Oil	0.875	3.206
HFO	0.85	3.114
LPG	0.819	3.000
LNG	0.75	2.750

Figure-5

2. V_{ref} is the ship speed, measured in nautical miles per hour (knot), on deep water in the maximum design load condition (Capacity)

3. Capacity is defined as follows:

3.1 For dry cargo carriers, tankers, gas tankers, containerships, ro-ro cargo and general cargo ships, deadweight should be used as Capacity.

3.2 For passenger ships and ro-ro passenger ships, gross tonnage should be used as Capacity.

3.3 For containerships, the capacity parameter should be established at 65% of the deadweight.

4. Deadweight means the difference in tonnes between the displacement of a ship in water of relative density of 1,025 kg/m³ at the deepest operational draught and the lightweight of the ship

5 P is the power of the main and auxiliary engines, measured in kW

6 V_{ref} , Capacity and P should be consistent with each other

7. SFC is the certified specific fuel consumption, measured in g/kWh, of the engines

8. f_j is a correction factor to account for ship specific design elements

9. f_w is a non-dimensional coefficient indicating the decrease of speed in representative sea conditions of wave height, wave frequency and wind speed (e.g., Beaufort Scale 6)

2.2 SHIP'S ENERGY EFFICIENCY MANAGEMENT PLAN (SEEMP)

In global terms it should be recognized that operational efficiencies delivered by a large number of ship operators will make an invaluable contribution to reducing global carbon emissions. The purpose of a Ship Energy Efficiency Management Plan (SEEMP) is to establish a mechanism for a company and/or a ship to improve the energy efficiency of a ship's operation. Monitoring of operational environmental efficiency should be treated as an integral element of broader company management systems. It is intended to be a management tool to assist a company in managing the ongoing environmental performance of its vessels and should be developed as a ship-specific plan. The SEEMP seeks to improve a ship's energy efficiency through four steps: planning, implementation, monitoring, and self-evaluation and improvement.

2.2 (a) Ship specific measures – variety of options to improve efficiency – speed optimization, weather routing and hull maintenance and also depending upon ship type, cargoes, routes and other factors

- determine and understand the ship's current status of energy usage
- identifies energy-saving measures that have been undertaken
- determines how effective these measures are in terms of improving energy efficiency
- identifies what measures can be adopted to further improve the energy efficiency of the ship

2.2 (b) Company specific measures – Improvement of energy efficiency of ship operation also depends on ship repair yards, ship owners, operators, charterers, cargo owners, ports, and traffic management services. Company also establish an energy management plan to manage its

fleet and make necessary coordination among stakeholders

2.2 (c) Human resource development – For effective and steady implementation of the adopted measures, raising awareness of and providing necessary training for personnel both on shore and on board are an important element.

2.2 (d) Self-evaluation – is to evaluate the effectiveness of the planned measures and of their implementation, to deepen the understanding on the overall characteristics of the ship’s operation such as what types of measures can/cannot function effectively and how and/or why, to comprehend the trend of the efficiency improvement of that ship, and to develop the improved SEEMP for the next cycle

2.3 ENERGY EFFICIENCY OPERATIONAL INDICATOR (EEOI)

It is an evaluation of the performance of the fleet with regard to CO₂ emissions. As the amount of CO₂ emitted from a ship is directly related to the consumption of bunker fuel oil, the EEOI can also provide useful information on a ship’s performance with regard to fuel efficiency. The EEOI should be a representative value of the energy efficiency of the ship operation over a consistent period which represents the overall trading pattern of the vessel.

$$EEOI = \frac{\sum_j FC_{ij} \times C_{Fj}}{m_{cargo} \times D}$$

$$Average\ EEOI = \frac{\sum_i \sum_j (FC_{ij} \times C_{Fj})}{\sum_i (m_{cargo,i} \times D_i)}$$

Where:

- j is the fuel type;
- i is the voyage number;
- FC_{ij} is the mass of consumed fuel j at voyage i;
- C_{Fj} is the fuel mass to CO₂ mass conversion factor for fuel j;
- m_{cargo} is cargo carried (tonnes) or work done (number of TEU or passengers) or gross tonnes for passenger ships; and
- D is the distance in nautical miles corresponding to the cargo carries or work done.

The unit of EEOI depends on the measurement of cargo carried or work done, e.g., tonnes CO₂/ (tonnes • nautical miles), tonnes CO₂/ (TEU • nautical miles), tonnes CO₂/ (person • nautical miles),

3. COASTAL SHIPPING IN INDIA

3.1 INDUSTRY SIZE AND GROWTH

3.1 (a) Vessels And Tonnage

Coastal shipping vessels operating in India have increased from 458 on 31 March 2005 to 700 vessels on 1 January 2011, with gross registered tonnage (GRT) of 0.8 million and 1 million, respectively. During the same period, the number of overseas shipping vessels has risen from 228 to 340 with GRT of 7.2 million tonnes and 9.2 million tonnes, respectively. During this period, the average cargo-carrying capacity of Coastal ships declined from 1,770 tonnes to 1,445 tonnes, while it decreased from 31,589 tonnes to 26,917 tonnes for overseas ships. The induction of smaller ships in the coastal and overseas segments has led to a decline in the average cargo-carrying capacity. During the past five years, the share of coastal shipping vessels in the total number of vessels operating in India has hovered close to 67%. The share of coastal shipping in the total shipping GRT has been almost stagnant at around 10%. During the past five years, coastal shipping has outpaced overseas shipping in terms of the growth in its number of vessels and GRT.

Coastal vessels and GRT

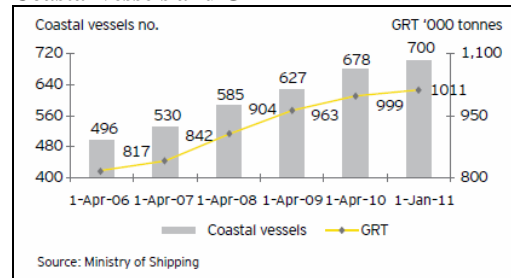

Figure-6

Percentage share of coastal shipping in total vessels and GRT

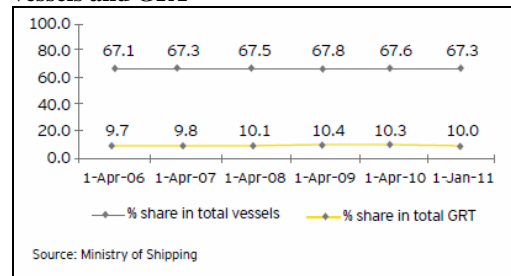

Figure-7

Growth comparison, coastal vis-à-vis overseas, in %

CAGR (2005-10)	Coastal	Overseas	Total
No. Of vessels	8.2	7.5	7.9
GRT	4.3	3.8	3.9

Figure-8

Coastal vessels, by category, as on 30 September 2010

Type of Vessel	No.	GRT	DWT
Tug	238	71,444	23,259
Offshore Supply Vessels	109	117,587	133,896
Port Trusts & Maritime Boards	93	45,184	15,831
Dry Cargo Liners	71	121,843	177,836
Passenger Services	55	16,701	1,930
Specialised Vessels for Offshore services	38	88,201	50,480
Passenger-cum-cargo	33	89,774	27,300
Dredgers	28	121,893	76,152
Product Tankers	13	40,035	43,226
Dry cargo bulk carriers	12	237,220	364,928
Ethylene gas carriers	3	8,727	6,558
Crude oil Tankers	2	50,080	82,246
Roll on Roll off	1	956	1,386
Total	696	1009645	1005028

Figure-9

3.1 (b) Traffic

Between 1999 and 2009, the coastal traffic at Indian ports increased at a Compound Annual Growth Rate (CAGR) of 4.7% from 84 million tonnes to 133 million tonnes. During the same period, coastal traffic at major ports increased at a CAGR of 3.7% from 72 million tonnes to 103 million tonnes, while coastal traffic at minor ports increased at a CAGR of 9.5% from 12 million tonnes to 30 million tonnes. Major ports account for around 77% of the country's coastal traffic, and among the minor ports, the Gujarat Maritime Board (GMB) ports account for a significant share. Currently, around 7% of the domestic cargo is transported through coastal shipping.

Petroleum, oil and lubricants (POL), thermal coal and crude account for major coastal traffic. Food grains, cement and containerized cargo, including cotton yarn, automobiles, automotive spare parts and steel are among the other key commodities shipped through the coastal mode. A miniscule portion of general cargo and finished products are transported through coastal shipping.

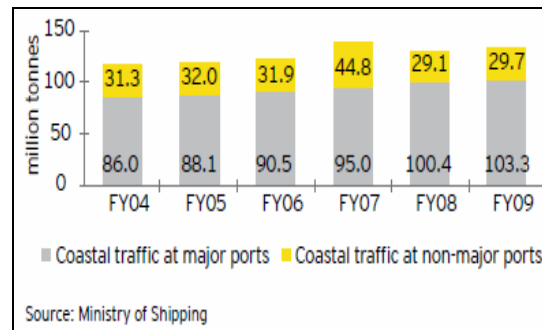

Figure-10

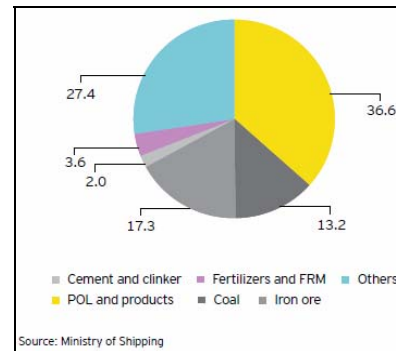

Figure-11

3.1 (c) Other Key Facts

India's coastal fleet is ageing fast. Around 52% of its tonnage is already overdue for replacement. As the passage of traffic is not equal in both the directions, coastal traffic movement is currently not balanced. This makes it necessary for coastal ships to sometimes sail in ballast on return journeys. The slow handling of cargo and undue delays at ports inflict heavy losses on coastal shipping companies. Around 70% of the ship time is estimated to be spent at ports and only 30% on voyages.

3.2 KEY TRENDS EXPECTED TO DRIVE COASTAL SHIPPING IN INDIA

3.2 (a) Rising Containerization

The share of container freight in total sea freight increased from 14.8% in FY04 to 18.0% in FY10. The trend of containerization is expected to boost the volumes shipped through coastal cargo. Due to the consolidation of large volumes, container cargo is suitable for transportation through coastal shipping.

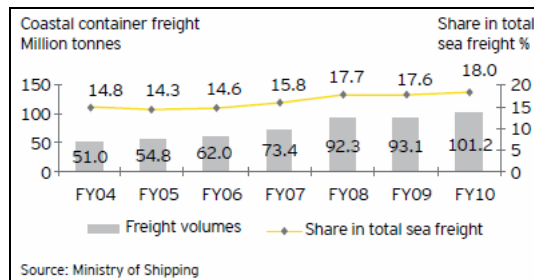

Figure-12

3.2 (b) Development of Transshipment Terminals

Transshipment is a process by which cargo is transferred from a large (mother) vessel to a small (feeder) vessel, through a port, and vice versa, without leaving the port. Currently, around 70% of the Indian container cargo is being transhipped at the ports of Colombo, Singapore, Dubai and Al Salalah. The transshipment from foreign ports makes a country's imports costlier and exports less competitive due to the increased transit time and additional port costs. The container transshipment terminal projects of the Vallarpadum and Vizhinjam ports are expected to give strong competition to the neighbouring ports of Singapore, Dubai and Colombo. The successful implementation of container transshipment projects is expected to drive Indian coastal shipping since container volumes are projected to flow to all the ports more rapidly than before. The strategic location of transshipment terminals makes them ideal for the inter-coastal movement of domestic Indian containers through coastal shipping.

3.2 (c) Development of Port-Based Special Economic Zone (SEZ) Projects

Port-based SEZ projects depend on coastal shipping for their logistical requirements. Coastal shipping is the least expensive and the most viable form of transportation for SEZ developers. The development of many port-based SEZ projects in Mundra, Rewas and other ports is underway. The proposed petroleum, chemical and petrochemical investment regions (PCPIRs) in Gujarat, Karnataka and Andhra Pradesh are also expected to drive the demand for coastal shipping. The port-based power projects rely on coastal shipping for the transportation of coal.

3.2 (d) Enhanced Focus on the Development of Minor Ports

Minor ports are the cornerstone of the Indian coastal shipping industry. They help reduce congestion at major ports. Dedicated coastal shipping ports can also enhance the efficiency of coastal shipping. The Government of India

launched the National Maritime Development Programme (NMDP) in 2005. This envisaged a total investment of INR1003 billion, including the implementation of 387 projects over a period up to FY12. The program, which includes ports (both major and minor), IWT and shipping projects, aims to increase capacity, improve the scope of private participation and enhance the quality of service and efficiency at ports. According to the NMDP, the minor ports in India are expected to witness investments worth US\$7.7 billion in the Eleventh Five Year Plan. The government is also planning to promote private-sector participation to develop minor ports. This project has been deferred due to low traffic.

3.3 KEY ADVANTAGES

The need for coastal shipping is evident in its various advantages over road and rail transport. Notwithstanding the need for road transport for last-mile connectivity, coastal shipping has the potential to reduce the overall cost of transportation. Here are the following advantages:

1. Coastal shipping is an environment-friendly and fuel efficient alternative to road and rail transport: The emission of harmful chemicals and gases such as carbon dioxide (CO₂), carbon monoxide and hydrocarbons, (except SO₂) is comparatively lower in coastal shipping. As such, this mode of transport reduces the adverse impact of pollution on health and the environment.

2. According to industry estimates, cargo vessels between 2,000 DWT and 8,000 DWT cause around 21 gm per tonne km of CO₂ emissions as compared to around 50 gm per tonne km caused by heavy trucks. Coastal shipping is therefore more fuel-efficient as compared to road and rail. Fuel consumption per tonne km is 31.33 grams by road, 8.91 grams by rail and 4.82 grams by coastal shipping.

3. Coastal shipping is a less expensive and faster mode of transportation: The cost of coast-to-coast transportation of goods by coastal shipping is much lower than that of other modes.

4. The cost of carriage by coastal shipping has been estimated at INR0.25 per tonne km, as compared to INR1.20 by road and INR0.60 by rail. However, this cost efficiency has not been realized because of insignificant volumes and the inefficiency of first/last mile connectivity.

5. According to the Ministry of Transport, the diversion of 5% of cargo transportation to a waterborne mode can result in an annual saving of around INR20 billion and a reduction of 6% in harmful chemicals and pollutants.

(Coastal shipping can also save time. For instance, according to a large cement player, which needs to transport 3,500 tonnes of cement from Kodinar in Gujarat to Mumbai, the entire process of

transportation by road would require 350 truck trips with a turnaround time of seven days for a distance of 700 km. This cargo can be transported more swiftly using a coastal vessel, which would take only around 24 hours to sail 300 km.)

6. Coastal shipping complements rail and road transport by providing a multi-modal integrated transport facility: Coastal shipping, together with road, rail and IWT, can substantially support the development of an integrated multi-modal transport system. This, in turn, can significantly reduce the overall cost of transportation. According to industry estimates, combining coastal and rail transportation can reduce the cost of transporting goods from north to south India and vice versa by around 40%–50%.

7. Coastal shipping is a safer mode of transportation: The diversion of cargo traffic to coastal shipping can help reduce road congestion, which, in turn, can reduce the loss of life and material caused by road accidents. Coastal shipping is safer for transporting hazardous and inflammable material, as road transport involves mobility through densely populated areas. The annual losses of more than INR300 billion are incurred due to road accidents, which result in more than 0.1 million lives lost annually.

8. Coastal shipping has the ability to transport large-sized cargo: Coastal shipping can handle and transport large-sized cargo such as project cargo more easily than rail and road transport, which is limited by carriageway restrictions. The inherent capacity and infrastructure limitations of rail and road transport restrict the movement of large and odd-shaped cargo.

Coastal ships travel close to the coast and their emissions from burning fuel oil directly affect the land based ecology. A recent study estimates that more than 50% of the emissions in the port terminals are from the ships. LNG fuel is a viable alternative to standard marine fuels. The environmental benefits of LNG as a fuel comprises of zero sulphur-oxide emissions and much lower CO₂ as well as significantly reduced nitrogen-oxide and particle emissions compared to standard marine fuels. Also the EEDI value is well below the baseline.

4. LNG

Liquefied natural gas or LNG is natural gas that has been converted temporarily to liquid form for ease of storage or transport. Its chemical composition comprises of predominantly Methane (CH₄) 87-99%, Ethane (C₂H₆) <1-10%, Propane (C₂H₈) >1-5%, Butane (C₄H₁₀) >1%, Nitrogen (N₂) 0.1-1%

and traces of other hydrocarbons. Liquefied natural gas takes up about 1/600th the volume of natural gas in the gaseous state. It is odorless, colorless, non-toxic and non-corrosive. Hazards include flammability, freezing and asphyxia. The liquefaction process involves removal of certain components, such as dust, acid gases, helium, water, and heavy hydrocarbons, which could cause difficulty downstream. The natural gas is then condensed into a liquid at close to atmospheric pressure (maximum transport pressure set at around 25 kPa/3.6 psi) by cooling it to approximately –162 °C (–260 °F). The energy density of LNG is 60% of that of diesel fuel and 70% of that of gasoline. The density of LNG is roughly 0.41 kg/L to 0.5 kg/L, depending on temperature, pressure and composition, compared to water at 1.0 kg/L. The heat value depends on the source of gas that is used and the process that is used to liquefy the gas. The higher heating value of LNG is estimated to be 24 MJ/L. The lower heating value of LNG is 21 MJ/L or 635 BTU/ft³. Its Carbon content is less i.e., 0.75 compared to HFO which is 0.85 (the basic reason for less emission of CO₂ in exhaust)

A typical LNG liquefaction and export terminal exporting 4.5 million tonnes of LNG can be expected to produce in the order of 1.2 million tonnes equivalent carbon dioxide of direct emissions. The greenhouse gas emissions associated with the combustion of 4.5 million tonnes of LNG is approximately 12 million tonnes equivalent carbon dioxide.

In its liquid state, LNG is not explosive and cannot burn. For LNG to burn, it must first vaporize, then mix with air in the proper proportions (the flammable range is 5% to 15%), and then be ignited. In the case of a leak, LNG vaporizes rapidly, turning into a gas (methane plus trace gases), and mixing with air. If this mixture is within the flammable range, there is risk of ignition which would create fire and thermal radiation hazards. LNG tankers have sailed over 100 million miles without a shipboard death or even a major accident.

Natural gas is consisting primarily of methane. A typical composition is:-Methane94%, Ethane4.7%, Propane0.8%, Butane0.2%, Nitrogen0.3%

Fuel		gr _{fuel} /MJ		gr _{CO2} /MJ		mgr _{SO2} /MJ
Natural Gas	CH ₄	20	-20 %	56	-30 %	0,1
Diesel Oil	-CH ₂ -	23	-8 %	73	-8 %	15
Heavy Fuel Oil	-CH ₂ -	25	100 %	79	100 %	250

Figure-13

FUEL	LHV (MJ/Kg)	Density (Kg/m3)	Energy density (MJ/m3)
MDO	42.7	900	38.430
LNG	54.7	442	24.177
LNG / MDO energy density ratio (same volume): 1.6			

Figure-14

Fuel type	SO _x (g/kWh)	NO _x (g/kWh)	PM (g/kWh)	CO ₂ (g/kWh)
Residual oil 3.5% sulphur	13	9-12	1,5	580-630
Marine diesel oil, 0,5%S	2	8-11	0,25-0,5	580-630
Gasoil, 0.1% sulphur	0,4	8-11	0,15-0,25	580-630
Natural gas (LNG)	0	2	~0	430-480

Figure-15

4.1 LNG BUNKER VOLUMES

One basic disadvantage of LNG is its low density: for the same energy content LNG takes roughly twice the volume of liquid fuels. Considering the existing “C” type (pressure vessels) cylindrical

bunker will lower the volumetric ratio down to 2 times.

4.2 TYPES OF LNG STORAGE

There are several types of containment systems for LNG available, but some are not feasible for the given conditions on ships using LNG as fuel following current designs. For example, most of the membrane tank systems as used on the very large LNG carriers are sensitive to sloshing and could therefore not carry partial loads – thus their use for fuel tanks is not possible. IMO type A (self-supporting tanks designed like ship structures) and type B (self supporting prismatic or spherical) tanks are generally feasible for fuel gas tanks, but their requirement for pressure maintenance and secondary barrier rise difficult problems that are not yet solved in a technically and commercially sound way. This will be a future solution for ships carrying large amounts of LNG as fuel.

LNG tank types

Tank type	Concept	Pressure	Partial Filling	2nd Barrier	Dis-Advantages	Advantages
Membrane, Semi-Membrane	Integrated in hull	<0.25 barg (max. 0.7)	No Some Yes	Yes	Very sensitive against pressure variations; Pressure holding necessary; Not gastight	Can be adapted to hull
Independent type						
A	prismatic with straight planes, adapted to hull shape	< 0.7 barg	Yes	Yes	Pressure holding necessary; Very voluminous vent system due to low pressure	Can be approx. adapted to hull shape
B	prismatic with straight planes, adapted to hull shape	< 0.7 barg	Yes	Partly	Pressure holding necessary; Very voluminous vent system due to low pressure	Can be approx. adapted to hull shape
	spherical (Moss)	< 0.7 barg	Yes	Yes	Pressure holding necessary; Space requirements	Very reliable system
C	Independent pressure vessel	> 2 bar	Yes	No*	Space requirements	- very solid design - Flexible pressure - Easy installation - No leakages occurred - No maintenance needed

* as per IGC code, under discussion for IGF code

LNG storage tanks, the

Figure-16

additional available space due to absence of conventional fuels installations: heating system with coils, purifiers, treatment units, bunkering, service-and settling tanks and considering tanks insulations, additional bulkheads, access trunks, vents, etc, LNG could require up to 2.5-3 times as much space as MDO for the same amount of energy onboard. The forthcoming installations of prismatic and membrane type tanks for LNG as



Figure-17

4.3 LNG PROCESS SYSTEMS

Basically the process system is intended to bring the LNG to the pressure and temperature level as required by the engines. Pressurising may be either done by small vaporisers keeping the entire tank on high operation pressure, by pumps serving the vaporisers or by compressors. All versions are feasible, the plant capacities and operational requirements will dictate the right solution tailor-made for each situation. In the basic system for a four-stroke engine an in-tank pump inside the type C tank is employed to feed the LNG fuel gas

vaporiser; the gas is provided to the engines via a fuel gas heater.

Also two-stroke engines will be available as dual-fuel engines quite soon. They require a different process system due to high injection pressure of 300 bar. On LNG carriers this can be done by BOG compressors, but for other ships this will only be a viable solution in some particular cases due to high capital expenditure, power requirements, size and weight of this equipment. High pressure pumps and high pressure vaporiser and heater are the preferred alternative to achieve the required pressure level. Tanks will usually be equipped with in-tank pumps to feed the high pressure system as well as the low pressure fuel gas supply to auxiliary engines.

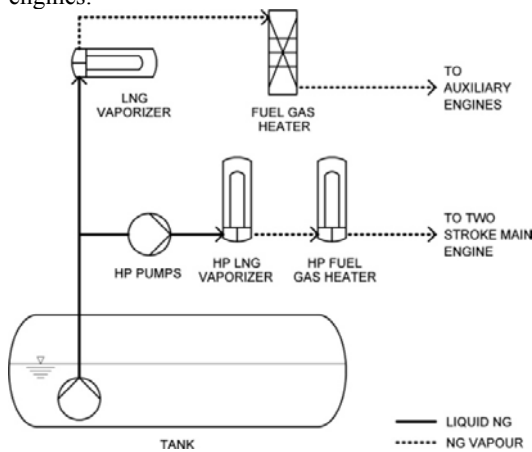

Figure-18

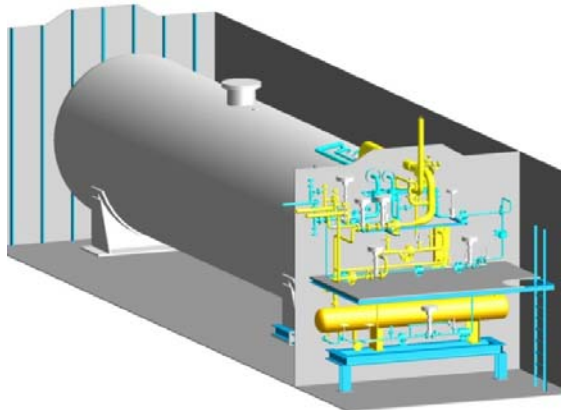
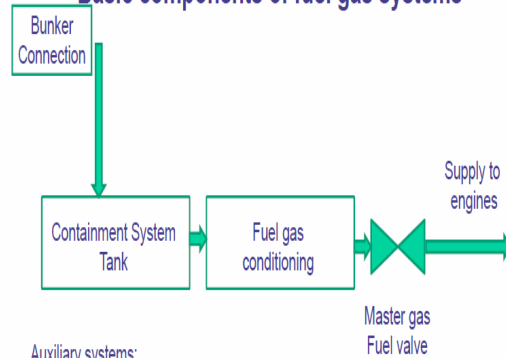

Figure-19

Basic components of fuel gas systems



- Auxiliary systems:
- water-glycol heating system
 - inert gas system
 - vent / ventilation
 - valve remote operation
 - safety systems
 - automation & control

Figure-20

4.4 LNG ON SHIPS OTHER THAN GAS CARRIERS – SAFETY SYSTEMS

With the use of gas on ships a number of hazards have to be addressed (e. g. fire, explosion, cold brittleness). IMO interim guideline MSC 285(86) as a preliminary version of IGF-Code and the Rules for LNG fuelled ships that have been published by all major classification societies are based on several decades of experience with LNG operations.

Double barriers for gas equipment, gas detection, ESD (Emergency Shut Down) systems and appropriately classed equipment are mandatory. Spill detection and stainless steel drip trays are located wherever LNG might escape and harm the ship structures by cold brittleness. Piping sections not in use are inerted with Nitrogen, e. g. bunkering line after bunkering is finished. Last but not least the control system and crew training will have significant influence on the safe operation of LNG installations.

5. DIESEL ELECTRIC PROPULSION SYSTEM

Most ships utilise reciprocating diesel engine as the prime mover due to its simplicity, robustness and fuel economy when compared with other prime movers like steam turbine, gas turbine, etc. From

an environmental point of view these are not environmental friendly. The good news though is that pollution levels are not equal across the working range. In the optimum operating range, fuel efficiency is considerably higher and pollution lower than at low speeds. Therefore, *the solution is to keep engines operating in this optimum range in all situations*. So the pollution levels are mostly dependant on i) the fuel being consumed and ii) the varying speeds & loads.

The first problem is addressed to by using LNG as an alternate fuel which reduces the emission of CO₂ by around 20%, SO_x by 100% and NO_x by 80%. However, when operating at low loads a phenomenon called Methane Slip is observed with LNG engines. This is nothing but escape of methane gas into atmosphere due to incomplete combustion of LNG. Methane is around 20 times more powerful than CO₂ as a greenhouse gas and release of even small volumes of methane easily spoils the potential gains achieved by the usage of LNG as alternate fuel. To prevent this from happening, at low loads the engine is changed over to conventional fuel. But usually this change-over is required mainly during manoeuvring operations when close to the coast for berthing, unberthing, etc. Again emitting more pollutants and that too close to the coast, which is not favourable.

Electric drive may be the solution to overcome the above mentioned problems. It not only reduces the pollutants in the emissions, but also increases the efficiency of the plant. This is due to the power plant principle where the power generation part consists of several engines operating in parallel and an optimum number of prime movers are always selected to match the load demand from the propellers and ship service load.

For vessels with electric propulsion one common power plant is utilized for both propulsion and cargo handling. This means that the total amount of installed power can be reduced with electric propulsion systems because the cargo handling plant and the propulsion plant are not used simultaneously. Using electric propulsion the dimensioning factor for the power plant would be the propulsion power plus the ship service load. This will mean a reduction of about 10% of installed power capacity, also there will be a positive impact on the manoeuvrability and crash stop situations.

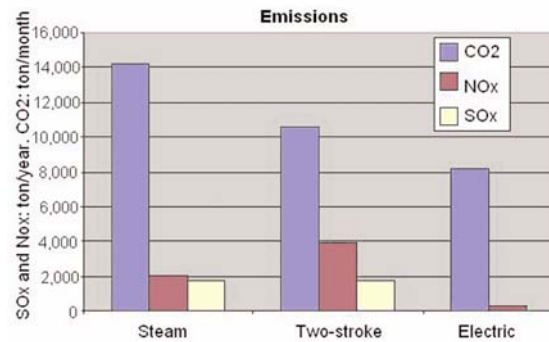

Figure-21

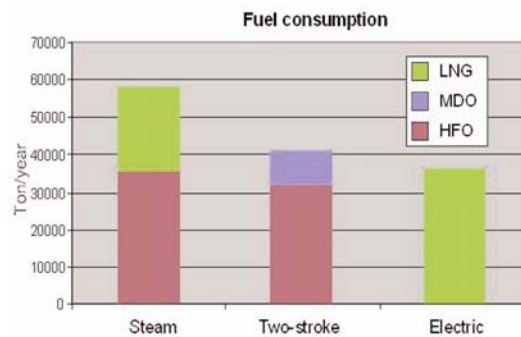

Figure-22



Figure-23

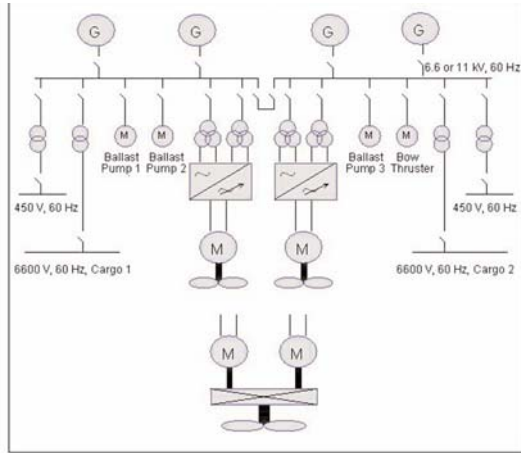

Figure-24

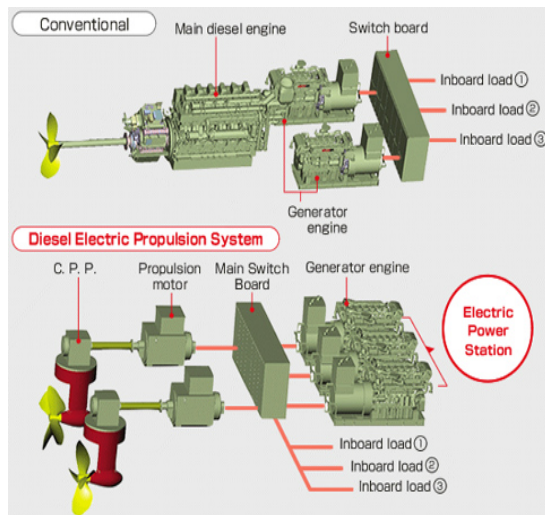

Figure-25

EQUIPMENT IN THE ENGINE ROOM FOR VARIOUS ARRANGEMENTS

5.1 ELECTRIC DRIVE

The electric propulsion system is a system in which the propeller is driven by electric power. It is a system that reduces life cycle costs, is highly economical and safe, and also environmentally friendly. In ordinary vessels, it is common for the main propulsion diesel engine to drive the propeller while the power for lighting or motors is supplied by engine generators. The diesel electric propulsion system provides electricity both for propulsion and on-board power needs.

As in all technologies electric drive systems have made substantial progress in recent years. The two

dominant systems available today are frequency controlled AC motors and SCR controlled DC motors. Frequency controlled AC motor drive systems are generally more cost effective below 500 H.P. and SCR controlled DC motor systems are more cost effective at the higher powers. The reason for the latter is the availability of new and rebuilt DC traction motors for railroad applications. Railroads and the offshore drilling industry have favoured SCR controlled DC drives, whereas the manufacturing industry has favoured frequency controlled AC motors due to the common requirement for lower power applications. Modern SCR and frequency controlled systems have efficiencies approaching 97% in power conversion. The selection of one over the other is an application issue. Both technologies have a proven record of efficiency and reliability.

Conventional propellers, CP propellers, azimuthing Z drives, transverse tunnel thrusters and low speed water jet systems can all be driven with equal effectiveness by a diesel electric system.

5.2 ENVIRONMENTALLY FRIENDLY SYSTEM

The medium-speed engines comply fully with the IMO TIER II NOx emission regulations and, compared to the low-speed engines used in conventional systems, they have lower NOx emissions. Featuring low vibrations and noise, these medium-speed generator engines also allow for more on-board comfort for the crew and greatly improve the work environment.

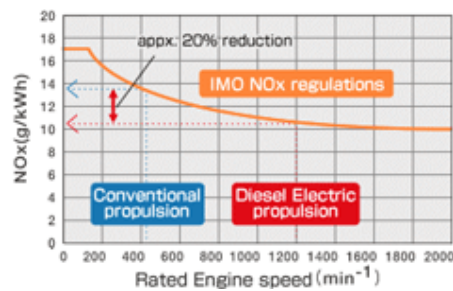

Figure-26

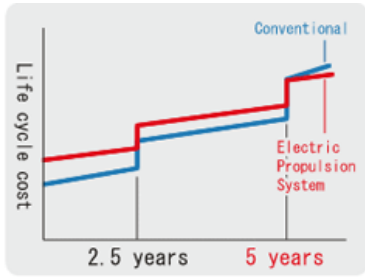

Figure-27

5.3 LOWER LIFE CYCLE COSTS COMPARED TO CONVENTIONAL SHIPS

Lower fuel and maintenance costs can be achieved with the Diesel Electric Propulsion System. It has been proven that life cycle costs after 5 years of operation are also lower than in the case of conventional ships.

5.4 COST REDUCTION THROUGH GENERATOR DECREASE

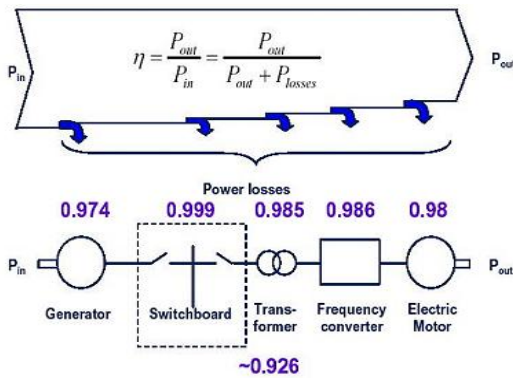

Figure-29

For each of the components, the electrical efficiency can be calculated, and typical values at full (rated) power are for; generator: $\eta = 0.95-0.97$, switchboard: $\eta = 0.999$, transformer: $\eta = 0.99-0.995$, frequency converter: $\eta = 0.98-0.99$, and electric motor: $\eta = 0.95-0.97$. So the cumulative efficiency for electrical transmission: $\eta = 0.88-0.92$.

The electric propulsion system incorporates the "Power Management System", which automatically manages the optimal number of power generators according to the propulsion load requirements. By having the generators always operate in the most efficient fuel consumption zone, fuel consumption is kept at a minimum.

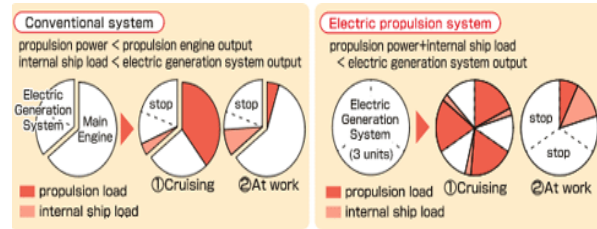

Figure-28

5.5 ADDITIONAL POWER LOSSES WHEN COMPARED WITH THE CONVENTIONAL DIRECT DRIVE

6. TECHNICAL AND ECONOMIC ANALYSIS OF VARIOUS PROPULSION SYSTEMS

6.1 CONVENTIONAL ENGINE

6.1 (a) Specifications

Main Engine Power – 3475 kw
 BSFC – 174 gm/kwhr @ 100% load for HFO
 Auxiliary Engine Power – 600 kw
 BSFC – 225 gm/kwhr @ 100% load for HFO
 Endurance – 10 days
 Total HFO to be carried – 260 M³/247MT
 Calorific value of HFO – ~43MJ/Kg
 Assuming 10% manoeuvring and 20% port stay
 Cost of HFO in India – 700 US\$ per ton
 Cost of MDO in India – 1000 US\$ per ton
 Cost of LNG in India – 900US\$ per ton
 No. of days in operation per year – 350 days

6.1 (b) Technical and Economic Analysis

During Sailing total HFO consumption per day (ME+1 AE) = 14.5 + (1*3.2) = 17.7 MT
 During Manoeuvring total MDO consumption per day (ME+2 AE) = 7.2 + (2*3.2) = 13.6 MT
 During Port Stay total MDO consumption per day (2 AE) = 2*3.2 = 6.4 MT

Total HFO consumption per year (70%) = 0.7*350*17.7 = 4336.5 MT
 Total MDO consumption per year(10% + 20%) = (0.1*350*13.6) + (0.2*350*6.4) = 924 MT

Total cost of HFO per year = 4336.5*700 = 3035550 US\$
 Total cost of MDO per year = 924*1000 = 924000US\$
 Total cost of Fuel consumed per year = 39,59,550 US\$

6.2 LNG DUAL FUEL ENGINE

6.2(a) Specifications

Main Engine Power – 3475 kw
 BSFC – 150 gm/kwhr @ 100% load for LNG
 BSFC – 174 gm/kwhr @ 100% load for MDO
 Auxiliary Engine Power – 600 kw
 BSFC – 194 gm/kwhr @ 100% load for LNG
 BSFC – 225 gm/kwhr @ 100% load for MDO
 Endurance – 10 days
 Dual Fuel – 95% LNG, 5% MDO as Pilot fuel
 Total LNG to be carried – 450 M³/202MT
 Density of LNG – 450kg/M³
 Calorific value of LNG – ~49.5MJ/Kg
 Calorific value of MDO – ~43.0MJ/Kg
 Assuming 10% manoeuvring and 20% port stay

6.2 (b) Technical and Economic Analysis

During Sailing total LNG consumption per day (ME+1 AE) = 0.95[12.5+2.8] = 14.5 MT
 During Sailing total MDO consumption (pilot fuel) per day = 0.05[14.5+3.2] = 0.9 MT
 During Manoeuvring total MDO consumption per day (ME+2 AE) = 7.2 + (2*3.2) = 13.6 MT
 During Port Stay total LNG consumption per day (2 AE) = 0.95[2*2.8] = 5.3 MT
 During Port Stay total MDO consumption per day (2 AE) = 0.05[2*3.2] = 0.3 MT

Total LNG consumption per year = (0.7*350*14.5) + (0.2*350*5.3) = 3923.5 MT
 Total MDO consumption per year = (0.7*350*0.9) + (0.1*350*13.6) + (0.2*350*0.3) = 717.5 MT

Total cost of LNG per year = 3923.5*900 = 3531150 US\$
 Total cost of MDO per year = 717.5*1000 = 717500US\$
 Total cost of Fuel consumed per year = 42,48,650 US\$

6.3 LNG DUAL FUEL ELECTRIC DRIVE

6.3 (a) Specifications

Auxiliary Engine Power – 3 * 1800 kw
 BSFC – 176 gm/kwhr @ 100% load for LNG
 BSFC – 205 gm/kwhr @ 100% load for MDO
 Endurance – 10 days
 Dual Fuel – 95% LNG, 5% MDO as Pilot fuel
 Total LNG to be carried – 450 M³/202MT
 Density of LNG – 450kg/M³
 Calorific value of LNG – ~49.5MJ/Kg
 Calorific value of MDO – ~43.0MJ/Kg
 Assuming 10% manoeuvring and 20% port stay

6.3 (b) Technical and Economic Analysis

During Sailing total LNG consumption per day = 0.95*3*5.4 = 15.4 MT
 During Sailing total MDO consumption per day = 0.05*3*6.4 = 1.0 MT
 During manoeuvring total LNG consumption per day = 0.95*2*5.4 = 10.2 MT
 During manoeuvring total MDO consumption per day = 0.05*2*6.4 = 0.6 MT
 During Port stays total LNG consumption per day = 0.95*5.1 = 4.8 MT
 During Port stay total MDO consumption per day = 0.05*5.9 = 0.3 MT

Total LNG consumption per year = 0.95 [0.7*350*15.4 + 0.1*350*10.2 + 0.2*350*4.8] = 4242.7 MT

Total MDO consumption per year =
 $0.05[0.7*350*1.0 + 0.1*350*0.6 + 0.2*350*0.3] =$
 14.3 MT

Total cost of LNG per year = $4242.7*900 =$
 3818430 US\$

Total cost of MDO per year = $14.3*1000 =$ 14300
 US\$

Total cost of Fuel consumed per year = 38,32,730
 US\$

6.3 (c) Equipment not needed (savings on
 equipment)

- Purifiers and associated machinery
- Purifier Room
- Exhaust Gas Boiler
- Auxiliary Boiler
- HFO Bunker Tanks
- HFO Service and Settling Tanks and its associated heating equipments
- HFO transfer and service pumps
- Sludge tank
- Auxiliaries Engines
- Exhaust Gas Scrubber to remove SO_x
- Selective Catalytic Reducers (To meet TIER III requirements)

6.3(d) Savings on carbon credits

The CO₂ emissions that are generated from the exhaust of LNG dual fuel electric drive propulsion are 20-30% less than that generated by a conventional liquid fuel engine, thus reducing the carbon foot print of the power plant. For the efforts put in mitigating the carbon foot print, carbon credits will be awarded which can be traded in the international market.

6.3(e) Additional equipment needed (expenses
 for equipment)

- 2 no. LNG bottles
- Cold box comprising of 2 sets of HP pumps, HP LNG Vaporiser, HP LNG heater and other associated equipment
- Ventilation system for annular spaces between fuel line and its outer protective pipe
- Additional safety features for fire protection
- Complicated Switchboard with additional frequency converters and transformers (electronics)
- Propulsion motor

6.3(f) Waste Heat Utilisation (for increasing
 thermal efficiency – additional advantage)

- A turbine in the exhaust uptake for producing electricity or
- Sterling engine in the uptake for producing electricity or
- Exhaust boiler to produce steam to run a turbo alternator

7. CONCLUSION

The dual fuel diesel electric propulsion system is gaining a strong position in the LNG shipping market especially in the coastal shipping. Presently in India the cost of LNG is high when compared with USA and Europe, but with the development of required infrastructure and with increase in demand, the local reserves in India can be put to use efficiently and at reduced prices. Then this proposition of using LNG for marine propulsion will become much more lucrative. For the set up of this system additional expenditure is involved for the LNG bottles, etc and also it will occupy around 1.5-3.0% of the cargo space. But this expenditure will be worthy in the long run as the benefits that are obtained are very rewarding – mainly the conservation of the environment and the reduction in not only the fuel costs but also the maintenance costs due to clean combustion.

8. ACKNOWLEDGEMENTS

We profoundly thank Dr. S.C.Misra, Director, IMU-V for his guidance and valuable inputs.

9. REFERENCES

1. Alexander Harsema-Mensonides, Dual Fuel Electric Propulsion Systems in LNG Shipping, internet website
2. Barend Thijssen, Wartsila, Dual-fuel-electric LNG carriers, LNG shipping operations, Hamburg, September 27. 2006
3. MEPC.1/circ.681, 17th August 2009
4. Ernst & Young, Indian Coast line, A new opportunity
5. IMO Study on Greenhouse Gas Emissions from ships 2009/2009, 16-18 February 2009
6. IEA Statistics, 2010 edition, CO₂ emissions from fuel combustion
7. Alf Kare Adnanes, ABB AS, Maritime electrical installations and diesel electric propulsion
8. MEPC 61/INF.2, 13th August 2010
9. ABS guide for Propulsion And Auxiliary Systems for Gas Fueled Ships
10. Jan Fredrik Hansen and Rune Lysebo, ABB AS Marine group, Norway, Electric propulsion for LNG carriers

11. Øyvind Buhaug, Scale and nature of emissions from Shipping, Seas At Risk annual conference, 5 November 2008, Brussels
12. ABS notes on Heavy Oil, 1984
13. MEPC59/24/Add.1, 28th July 2009

10. AUTHOR'S BIOGRAPHY

Srinivas Vissamsetty holds the current position of Scientist-C at Indian Maritime University, Visakhapatnam. He is a project associate for the project "Conducting Safety Assessment Studies on Passenger Vessels in Andaman Nicobar Islands, Lakshadweep Islands And Inland Waters". He had sailing experience as Chief Engineer on Merchant Navy cargo vessels.

Ramesh S Upadhyayula holds the current position of Chief Manager at Indian Maritime University, Visakhapatnam. He is the project incharge for the project "Study of Emissions from Vessels operating in Indian Coast, Inland Waterways & Harbour craft". His previous experience includes sailing experience as Chief Engineer on Merchant Navy cargo vessels, dredgers.